

ELECTRONICS

Introduction

The OneControl® ConnectAnywhere™ is an electronic control system that allows worldwide remote control of LCI OneControl-compatible Controller Area Network (CAN) controllers.

This document provides instructions on how to activate the ConnectAnywhere system and associate it to the LCI Customer Community website.

Resources Required

ConnectAnywhere parts needed for system activation (Fig. 1):

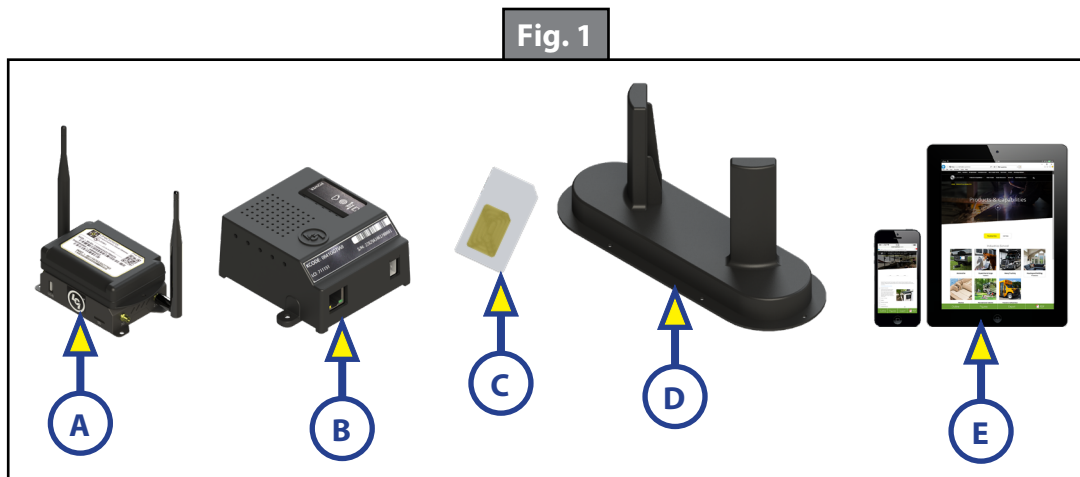

Callout	Description
A	ConnectAnywhere Cellular Gateway
B	ConnectAnywhere Cloud Gateway
C	Nano SIM Card (carrier-provided)
D	External Roof Mount Antenna
E	Android or iOS Smart Device

ELECTRONICS

Preparation

1. Locate the ConnectAnywhere hardware (Fig. 2).

NOTE: The ConnectAnywhere hardware is typically located in a cabinet in the middle of the unit (Fig. 2A) or in a pass-through storage unit (Fig. 2B). Refer to the unit's floor plan or User Guide for additional information.

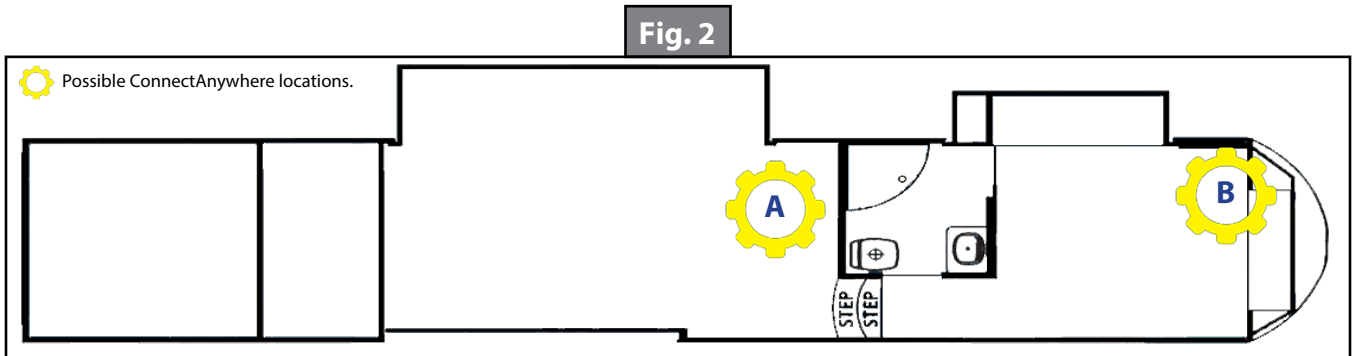

Fig. 2

2. Record the following information from the cellular and cloud gateway labels for later use:
 - **SSID** (Fig. 3A)
 - **PASSWORD** (Fig. 3B)
 - **IMEI** (Fig. 3C)
 - **KCODE** (Fig. 4A)

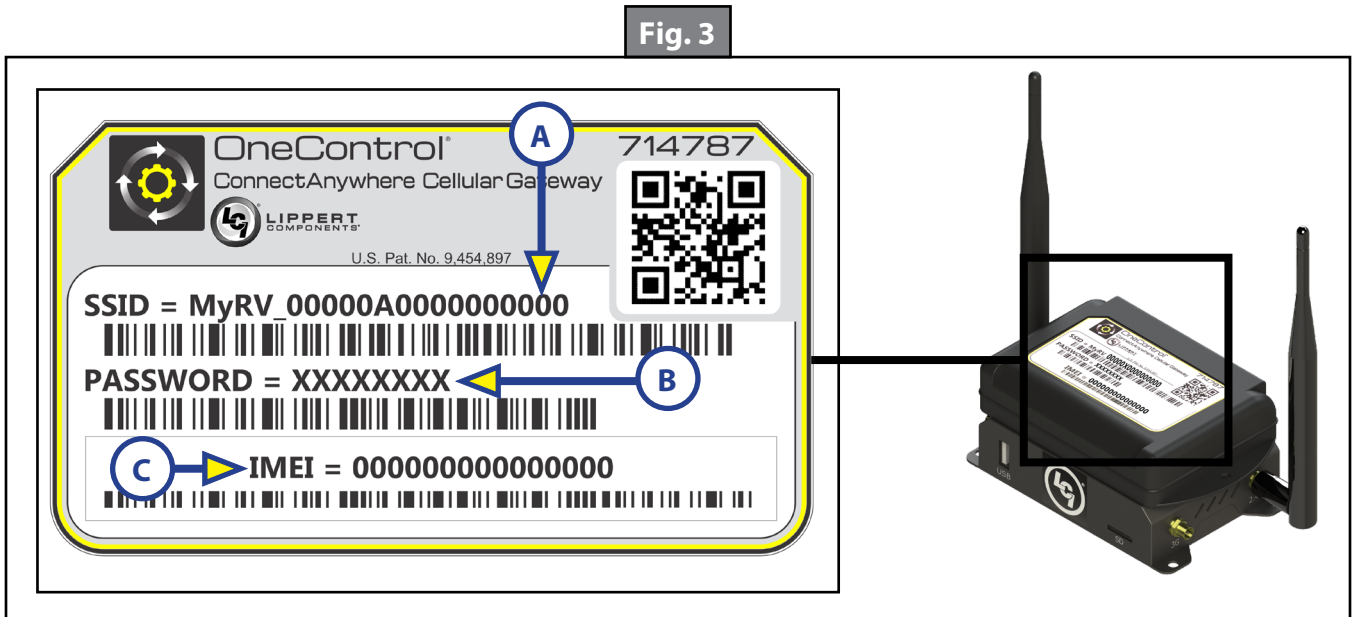
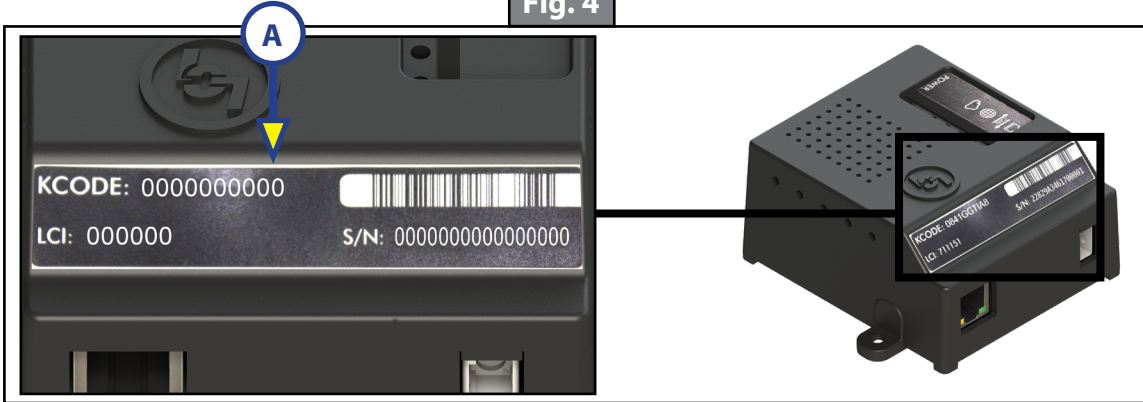

Fig. 3

ELECTRONICS

Fig. 4



Data Package Required

ConnectAnywhere® is certified with AT&T® and Rogers™ (CAN) cellular service using 3G bands II, IV, V and 4G LTE bands 2, 4 & 12.

- Purchase of a nano sim card and data package is required.

The AT&T® and Rogers™ (CAN) trade names and logos are registered trademarks of AT&T® and Rogers™ (CAN) respectively.

Activation of the ConnectAnywhere system requires access to an existing Internet connection† and the use of an AT&T or Rogers standard size SIM card and data package.

CAUTION

The IMEI number is a unique 15-digit serial number given to every mobile phone. The IMEI number should be treated and protected the same as a Personal Identification Number (PIN) to prevent unauthorized access to the system. Use care when placing additional product labels that show product-sensitive information, such as SSID, PASSWORD and IMEI number.

Before visiting AT&T® or Rogers™ (CAN), make sure to have the **IMEI** (International Mobile Equipment Identity) number available. The **IMEI** number is printed on the OneControl ConnectAnywhere Cellular Gateway label (Fig. 3C).

NOTE: The **IMEI** number is a unique 15-digit serial number given to every cellular mobile device, which can then be used to check information such as the phone's Country of Origin, the Manufacturer and it's Model Number.

Whether currently an AT&T Wireless or Rogers (CAN) customer or not, contact AT&T or Rogers (CAN) customer service or visit the nearest AT&T Wireless or Rogers corporate store to get either a standard size SIM card, or a nano size SIM card for insertion into the provided SIM card adapter (Fig. 1D).

Make sure to have the provider set up the SIM card for a hotspot.

†System connectivity is subject to carrier coverage map.

ELECTRONICS

If using a standard size SIM card, do as follows:

1. Disconnect power from the cellular gateway (Fig. 5A).
2. Locate the SIM card slot on the side of the cellular gateway (Fig. 6A).
3. Inspect card slot for provided SIM card adapter. If installed, remove adapter. Press and release card adapter to eject it from the slot.
4. With the new SIM card's contacts facing up (Fig. 6B), and the beveled edge on the top right hand corner, insert the SIM card into the SIM slot on the side of the gateway until a "click" sound is heard.

NOTE: The "click" sound means the SIM card is now securely latched into the SIM slot.

5. Make sure the SIM card is firmly seated, then reconnect previously disconnected power supply (step 1).

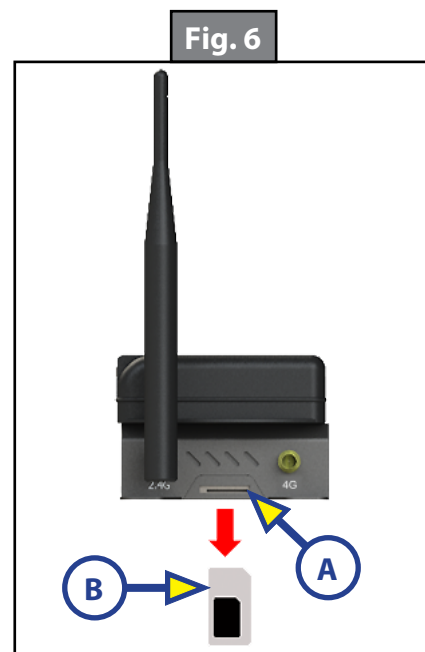
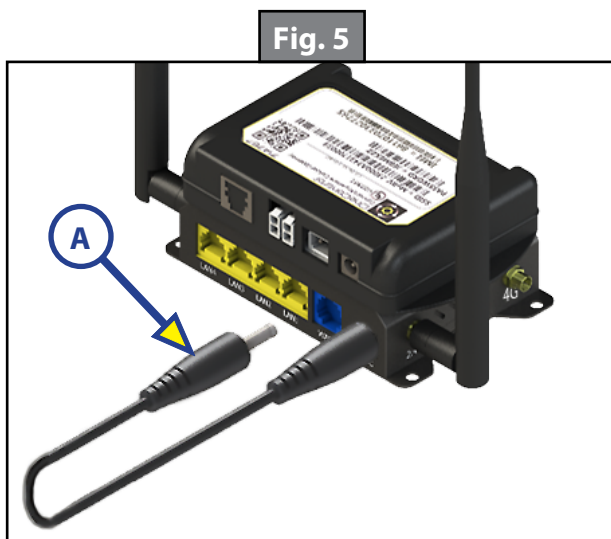

If using a nano size SIM card, do as follows:

1. Disconnect power from the cellular gateway (Fig. 5A).
2. Locate the SIM card slot on the side of the cellular gateway (Fig. 6A).
3. Inspect card slot for provided SIM card adapter. If installed, remove adapter (Fig. 6B). Press and release card adapter to eject it from the slot.
4. Place the nano SIM card into the nano SIM card adapter, aligning the beveled edge of the card with the beveled edge of the adapter (Fig. 7).
5. With the SIM card's contacts facing up (Fig. 6B), and the beveled edge on the top right hand corner of the adapter, insert the card into the SIM slot on the side of the gateway until a "click" sound is heard.

NOTE: The "click" sound means the SIM card is now securely latched into the SIM slot.

6. Make sure the SIM card is firmly seated, then reconnect previously disconnected power supply (step 1).

ELECTRONICS

Fig. 7

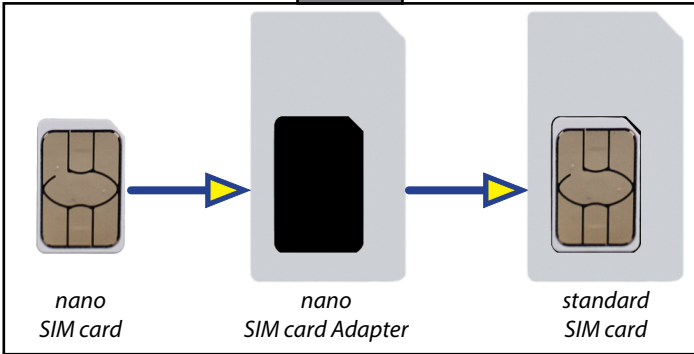

Download (Fig. 8A) and install (Fig. 8B) the LCI OneControl app from either Apple's App Store (iOS) or Google Play (Android).

Fig. 8

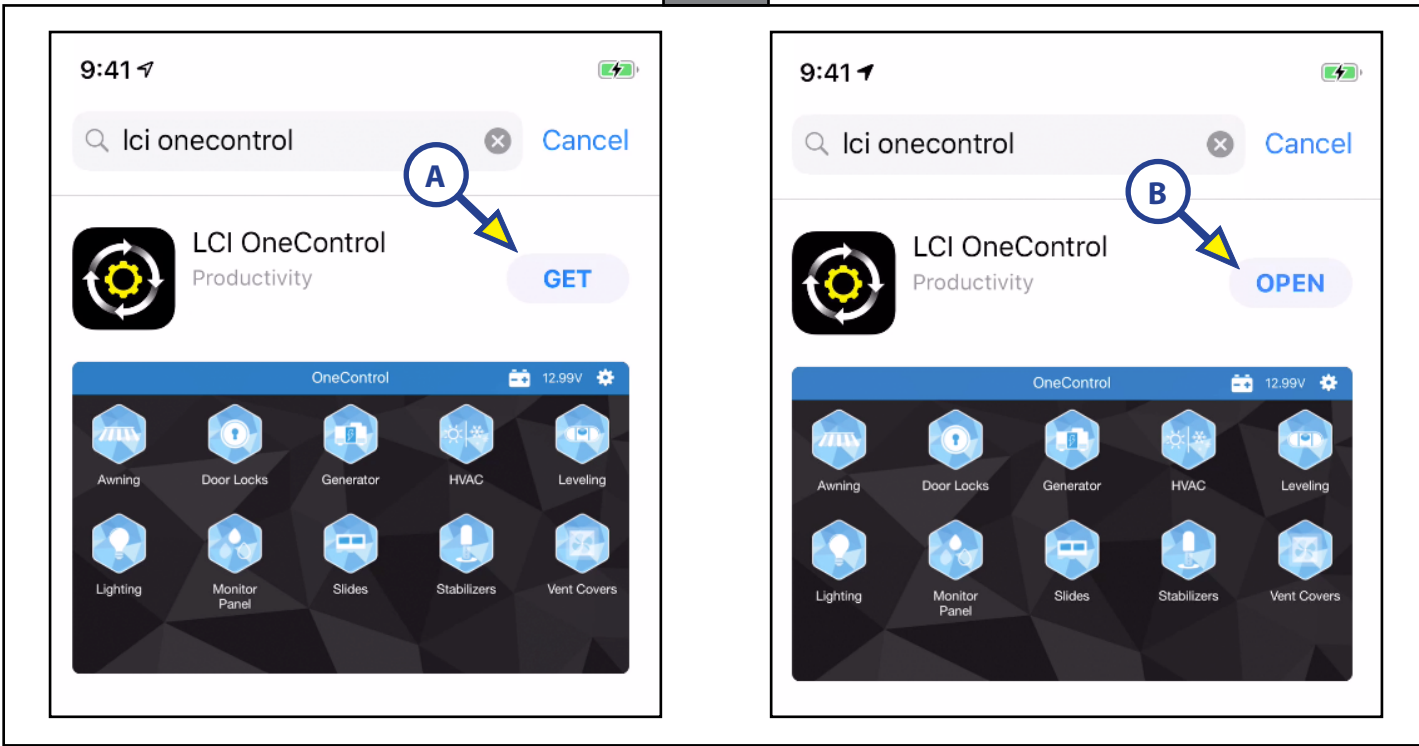

App Store® is a trademark of Apple Inc. Android™ and Google Play™ are trademarks of Google LLC.

Activation

NOTE: Screen images vary depending on the device used to register, activate or operate the OneControl ConnectAnywhere system. The following screen captures (Figs. 9-13) reflect an iOS smart device.

Connecting to A Secured Wi-Fi Network

Secured Wi-Fi networks are password-protected. An image of a closed lock  will appear next to its name. To connect to a secured Wi-Fi network, do as follows:

NOTE: Terms used are from an iOS device—Android device terms may differ slightly.

1. On mobile device being used, go to Settings > Wi-Fi (Fig. 9). Make sure the Wi-Fi setting is turned on.

Fig. 9

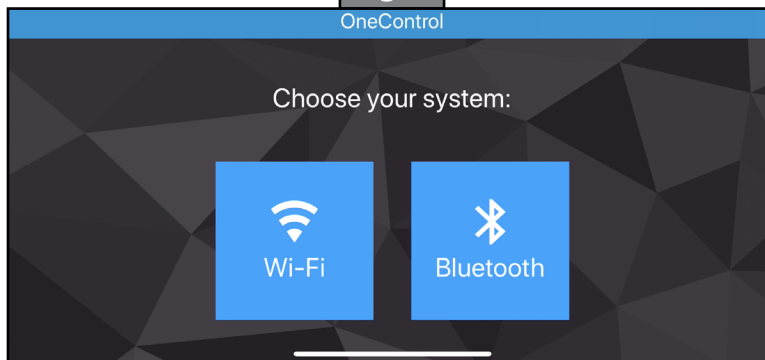

ELECTRONICS

2. Select the name of the desired, secured Wi-Fi network (Fig. 10A).
NOTE: This network name will be the **SSID** name (Fig. 3A) printed on the cellular gateway label.
3. Enter the **PASSWORD** (Fig. 11) located on the cellular gateway label (Fig. 3B).
NOTE: Passwords are case sensitive and do not contain numerals . Use care when typing the **PASSWORD**.
4. Click on Join (Fig. 11A).
5. If Join is inactive, then the wrong **PASSWORD** was entered. Repeat steps 3 and 4.

Fig. 10

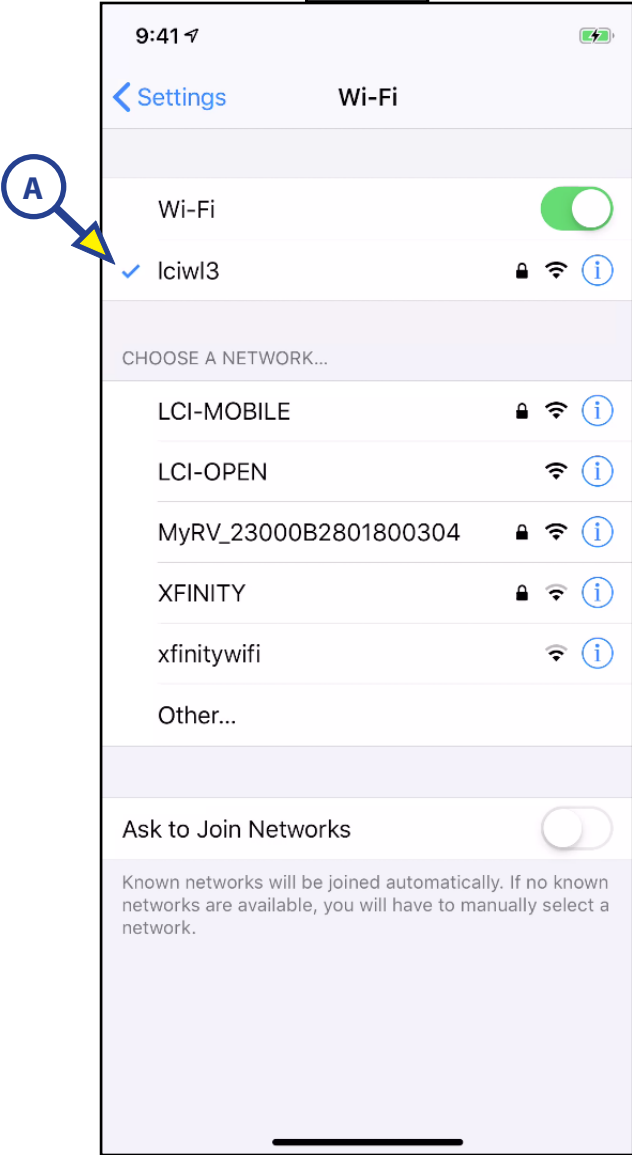
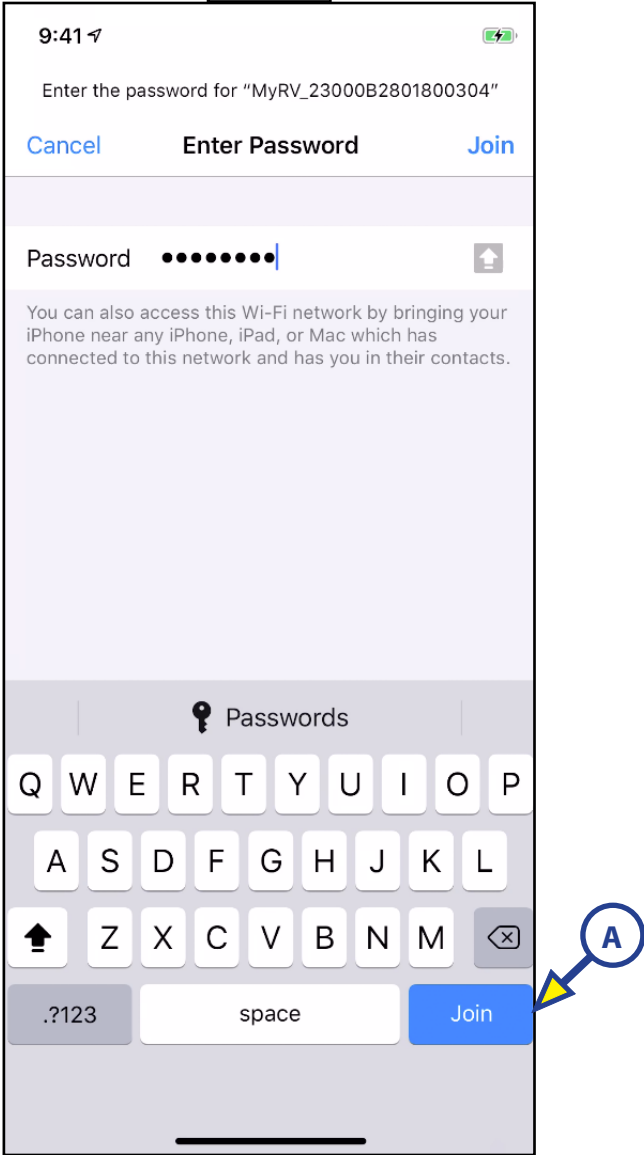

Fig. 11



ELECTRONICS

6. When joined with the network, a check mark ✓ will appear next to the network name (Fig. 12A) and the connectivity symbol  will appear in the upper left corner of the mobile device's display.
7. Verify connectivity by opening a web browser on the mobile device and navigate to www.lci1.com/onecontrol.
8. If the OneControl web page displays (Fig. 13), then the mobile device is connected. If the web page does not display, repeat steps 1-7.

Fig. 12

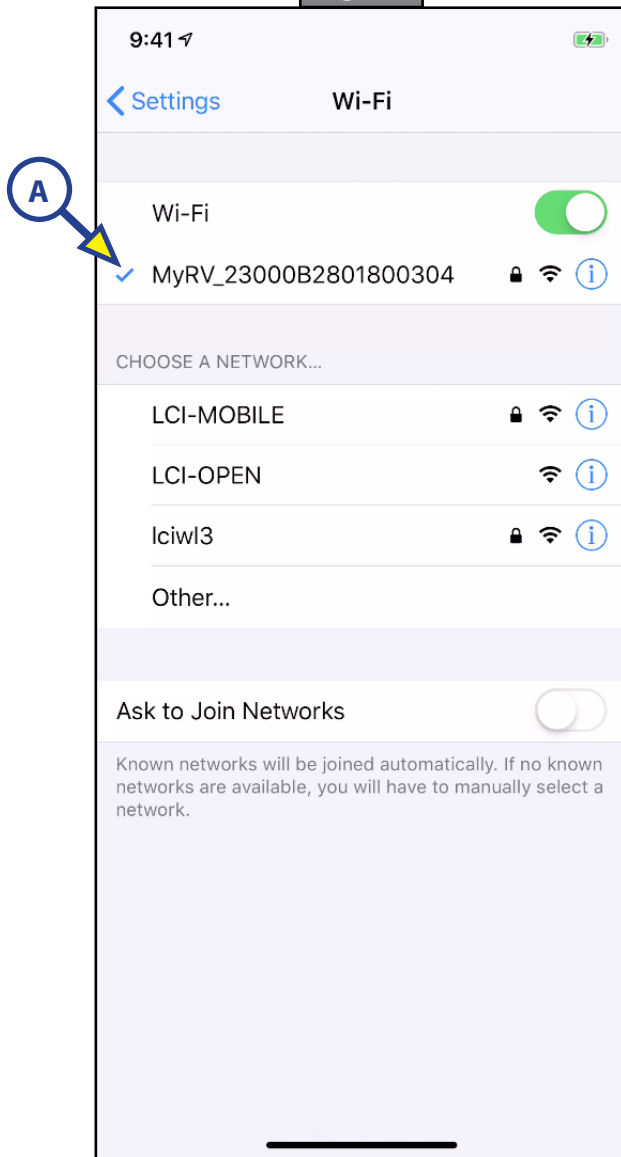
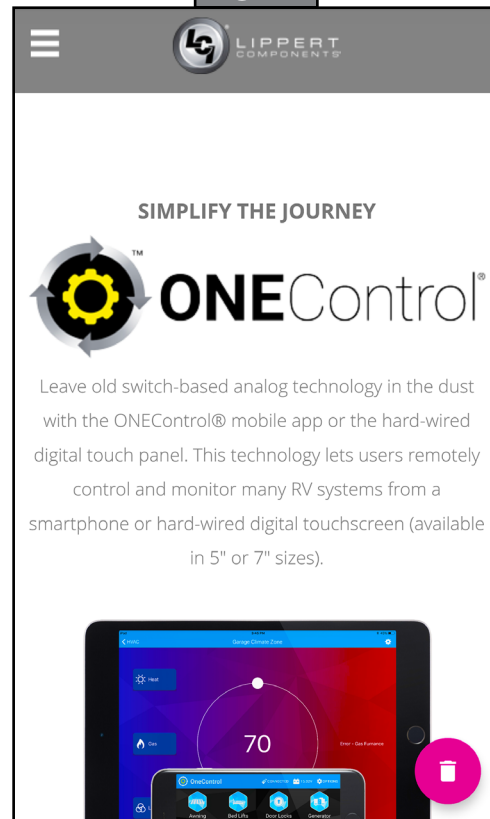

Fig. 13



ELECTRONICS

System Registration

The **KCODE** (Fig. 4A) is automatically read during activation when using the OneControl app.

NOTE: If registering on-line using a desktop or laptop PC, the **KCODE** will have to be entered manually.

To register the ConnectAnywhere system, do as follows:

1. Go to <https://lippert.force.com/loTCommunity/register>.
2. Follow the program prompts (Fig. 14).

Fig. 14

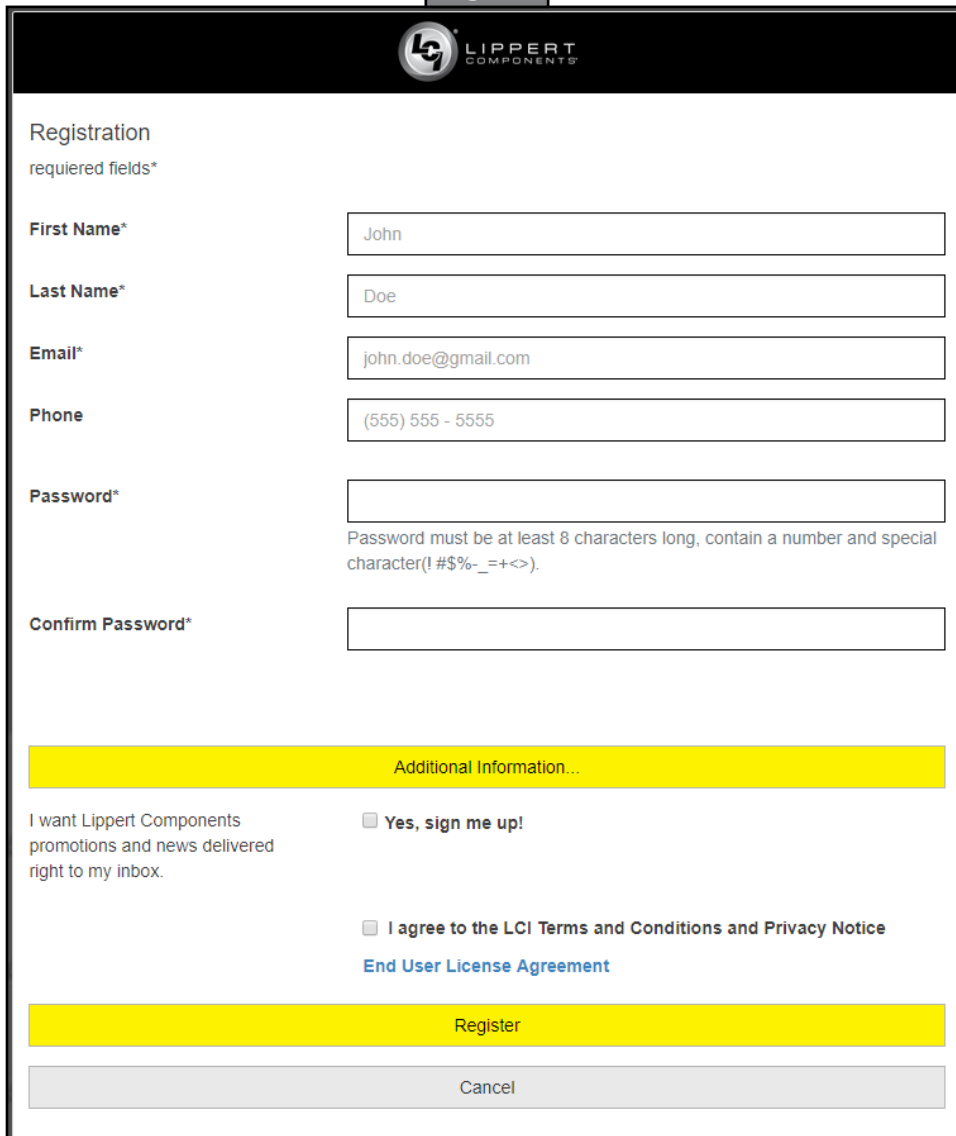

The screenshot shows a web registration form for Lippert Components. At the top is the Lippert Components logo. Below it, the text "Registration" and "required fields*" is displayed. The form contains several input fields: "First Name*" with the value "John", "Last Name*" with "Doe", "Email*" with "john.doe@gmail.com", "Phone" with "(555) 555 - 5555", "Password*", and "Confirm Password*". A note below the password field states: "Password must be at least 8 characters long, contain a number and special character(! #\$_-_=+<>)." Below the input fields is a yellow bar labeled "Additional Information...". Underneath, there are two checkboxes: "I want Lippert Components promotions and news delivered right to my inbox." with the option "Yes, sign me up!" selected, and "I agree to the LCI Terms and Conditions and Privacy Notice" with a link to "End User License Agreement". At the bottom are two buttons: a yellow "Register" button and a grey "Cancel" button.

ELECTRONICS

3. After completing setup, log into the LCI OneControl app by selecting the Menu (cog wheel) (Fig. 15A).
4. Enter login credentials, then click the Login button (Fig. 16A).

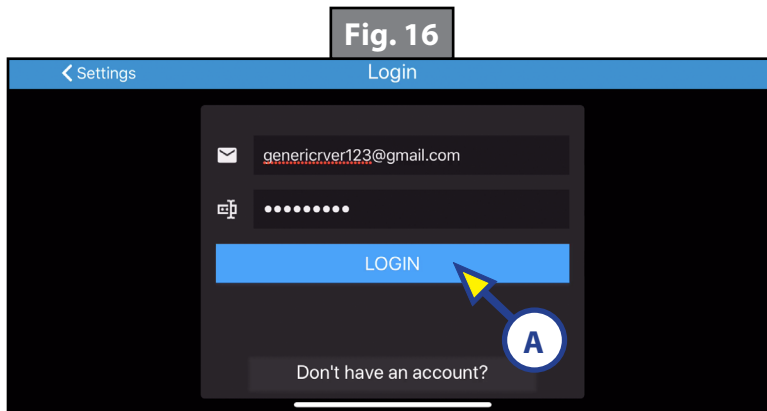
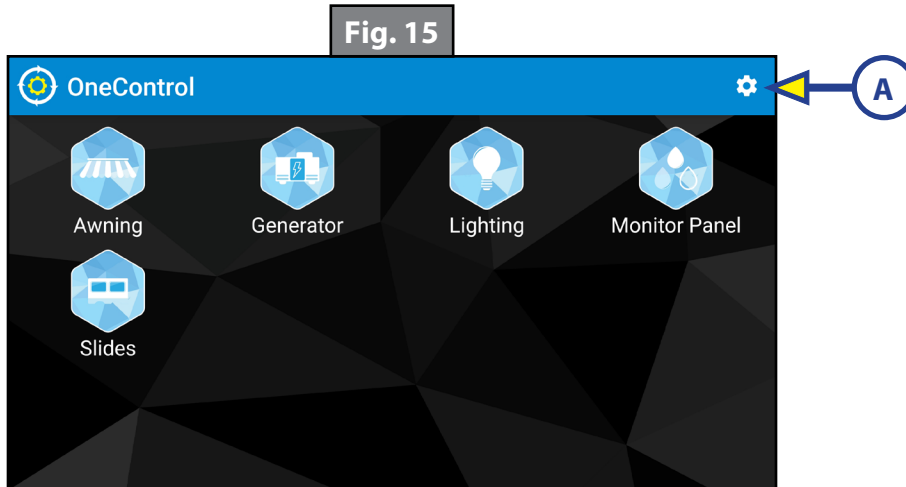

ConnectAnywhere system registration is now complete (Fig. 17).

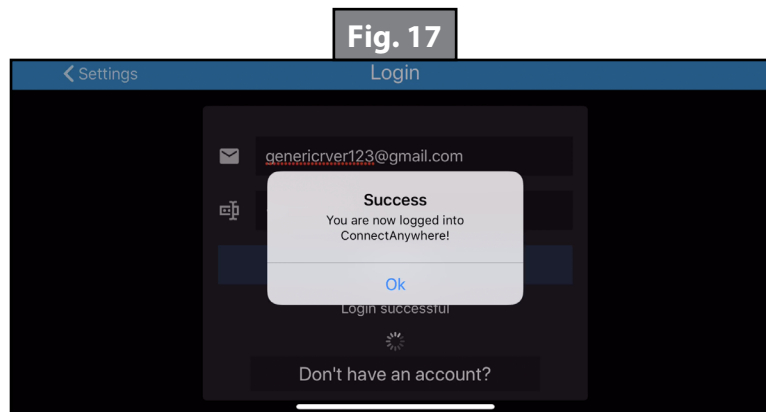

As a supplier of components to the RV industry, safety, education and customer satisfaction are our primary concerns. Should you have any questions, please do not hesitate to contact us at (574) 537-8900 or by email at customerservice@lci1.com. Self-help tips, technical documents, product videos and a training class schedule are available at lci1.com or by downloading the MyLCI app.